

AMERICAN EAGLE

DRAWER SYSTEMS



AMERICAN EAGLE

American Eagle drawer sets are engineered to withstand extreme levels of use and abuse!

- Certified* 500 lb. rated heavy-duty slides for durability and effortless operation.
- Standard and custom sizes and configurations available.
- All steel construction for superior strength and long life.
- Drawer fronts are powder-coated gray for a great looking, long lasting finish.
- All unpainted components are galvanized for rust free durability (and no chipped paint like many competitive units).
- Single T-shaped handle for convenient one-handed operation.
- Easy installation.
- Designed and manufactured by American Eagle, an employee owned company located in Garner, Iowa.
- Lifetime warranty on slides and hardware.

**Certified by SGS, a leading inspection, verification, and certification company.*

DRAWER SYSTEMS



*Designed & Manufactured
in the USA*



WHY AMERICAN EAGLE SHOULD BE YOUR



Four dividers are included in each drawer for tool organization. Egg crate dividers are also available for small parts storage.



Galvanized components with powder coated drawer fronts for a great appearance and long lasting durability.



Drawer edges are hemmed for added strength.



Single handed T-shaped latch for convenient one-handed access. All drawers are keyed for security.

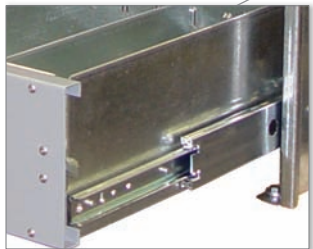

Certified* heavy-duty 500 lb. drawer slides for superior strength.

ANGLE CHOICE



Telescoping top shelf for easy installation. A space-saving flattop is also available.



Removable drawers for:

1. Ease of installation.
2. Move tools closer to your work.
3. Quick retrieval of lost or jammed tools.

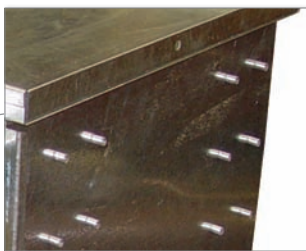
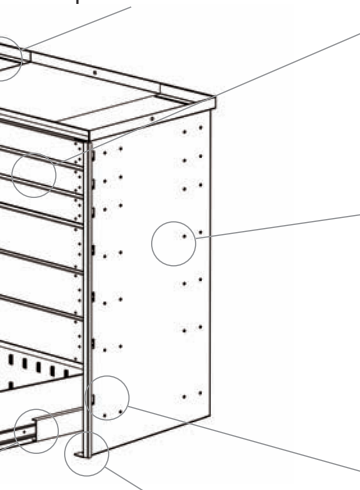

Heavy-duty 14-gauge steel sides for durability.



Standard 2.50" riser built-in with slotted mounting holes for quick installation. *(No riser or special riser kits also available).*



Concealed latching hardware and latch-guard for durability and security.

AMERICAN EAGLE

Shop Tool Box

Need a drawer system for your shop?

A heavy-duty enclosure is available for all drawer systems, which includes:

- Heavy 10-gauge powder-coated gray steel top for long life and to use as a work surface or shelf.
- Heavy-duty galvanized steel side and back panels for a strong attractive finish.
- Four heavy-duty (700 lb.) casters for easy rolling and durability.



4

American Eagle Accessories Group
Drawer Systems

DRAWER SYSTEMS

Bolt Bins

American Eagle bolt bin units are an excellent storage system for nuts, bolts, fittings, and more!

- Constructed of heavy 16-gauge steel – more than twice the thickness of similar competitive units to withstand rough use.
- Entire units, inside and out, are painted with chip-resistant powder paint for an attractive appearance and superior durability.
- Built-in pull style handle for easy access.
- Base angles downward so bins remain in, except when accessed.
- Spot-welded for durability and simple bolt-down construction for rigidity and quick installation - ready-to-use right out of the box.
- Each bin includes 3 removable aluminum dividers (7 slots per drawer) so each bin can be custom configured.
- Many standard configurations to choose from, and custom units are available to fit your needs.
- Bins measure 4 1/8”H x 6 3/4”W x 17 1/4”D for plenty of storage room.



***Design the drawer set how you want it...
and we'll make it!***

What we can do for you:

- 12" – 50" wide (in even inch increments)
- 10" – 60" deep (in even inch increments)
- Drawer heights of 3", 5" and 7"
- Standard 2.5" riser height

Options:

- No riser and special riser kits
- Space saving flat top
- Egg crate dividers
- Full enclosures with casters
- Hinged work top trays
- Special hanging configurations
- Quick design and manufacturing lead-time

Other ideas? Call us! We are here to make your job easier!

A drawer set measurement guide is available on the website: **www.americaneagleacc.com**



*What work trucks
are built around.*

190 State Street

P.O. Box 169

Garner, IA 50438

Telephone: (641) 923-2425 • (800) 392-3015

Fax: (641) 923-9099

Internet: www.americaneagleacc.com

Email: sales@americaneagleacc.com

Specifications may change without notification.

Copyright © 2010 American Eagle Accessories Group

The American Eagle logo is registered in the U.S. Patent and Trademark Office.